

Mira Select Flex Thermostatic Mixer

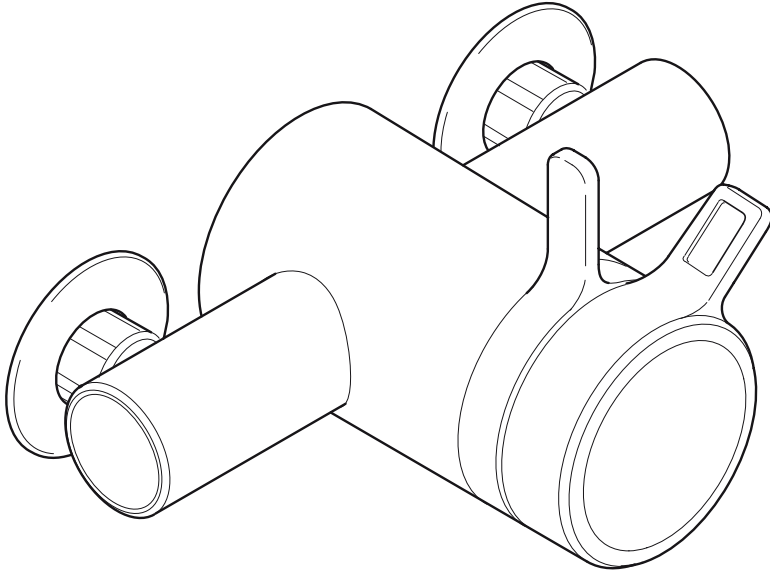

These instructions must be left with the user

Installation and User Guide

Showering perfection

mira
SHOWERS

INTRODUCTION

Thank you for purchasing a quality Mira product. To enjoy the full potential of your new product, please take time to read this guide thoroughly. Having done so, keep it handy for future reference.

The Mira Select Flex is a thermostatic mixer with separate flow and temperature controls. The lever controls have been designed to be easily operated by users with restricted hand movement.

The thermostatic mixer incorporates a wax capsule temperature sensing unit, which provides an almost immediate response to changes of temperature of the incoming water supplies to maintain the selected showering temperature. An adjustable temperature stop is provided which limits the maximum temperature to a safe level. Inlet filters are fitted to protect the thermostatic cartridge.

On exposed models the thermostatic mixer has adjustable inlets to fit pipework centres between 139 mm and 153 mm and is designed for connection to rising, falling or rear entry pipework.

The Mira Select Flex has been certified for use in UK Healthcare premises as a Type 3 valve under the BUILDCERT TMV3 scheme. The Mira Select Flex has also been certified as a Type 2 valve under the BUILDCERT TMV2 scheme. For Healthcare* installations refer to the TMV3 requirements manual. This product also complies with the Water Supply (water fittings) Regulations 1999.

*Healthcare applications are hospitals, aged person facilities, residential care homes, etc. and any other application where the user is similarly at risk.

The approved designations for Type 2 and Type 3 products are as follows:

Model	Designation
Mira Select Flex	LP-S, HP-S

Important! The fitting of any flow regulator will invalidate TMV2 or TMV3 compliance due to the minimum flow rate requirements. Do not fit flow regulators in TMV2 applications.

For Type 2 or Type 3 Valves refer to the TMV2 or TMV3 Requirements Manual.

If you experience any difficulty with the installation or operation of your new thermostatic mixer, please refer to '**Fault Diagnosis**', before contacting Kohler Mira Ltd. Our contact details can be found on the back cover of this guide.

GUARANTEE

For **domestic installations**, Mira Showers guarantee the Mira Select Flex against any defect in materials or workmanship for a period of **five** years from the date of purchase (shower fittings for one year).

For **non-domestic installations**, Mira Showers guarantee the Mira Select Flex against any defect in materials or workmanship for a period of **one** year from the date of purchase.

For terms and conditions refer to the back cover of this guide.

RECOMMENDED USAGE

Application	Valve Only	Valve with Fittings
Domestic	✓	✓
Light Commercial	✓	✓
Heavy Commercial	✓	✗
Healthcare	✓	✗

Note! Heavy duty shower fittings are available separately for use in Healthcare and Heavy Commercial applications, for details contact Customer Services.

PATENTS AND DESIGN REGISTRATION

Patents:

GB: 2 291 693, 2 392 225, 2 421 297

US: 7 240 850

Euro: 1 672 257 DE, FR, GB, IT, NL, SE

Patent Applications:

GB: 2 435 077, 0712546.1

US US-2006-0124758

US-2007-0221740

Euro: 03254070.0

Design Registration:

000834007/01, 000834007/02, 000578463-0006

SAFETY WARNINGS

WARNING - This product can deliver scalding temperatures if not operated, installed or maintained in accordance with the instructions, warnings and cautions contained in this guide.

The function of a thermostatic mixing valve is to deliver water consistently at a safe temperature. In keeping with every other mechanism, it cannot be considered as functionally infallible and as such, cannot totally replace a supervisor's vigilance where that is necessary. Provided it is installed, commissioned, operated and maintained within manufacturers recommendations, the risk of failure, if not eliminated, is reduced to the minimum achievable.

Caution!

1. Read all of these instructions and retain this guide for later use.
2. Installation must be carried out in accordance with these instructions, and must be conducted by designated, qualified and competent personnel.
3. Pass on this guide in the event of change of ownership of the installation site.
4. Follow all warnings, cautions and instructions contained in this guide.
5. Make sure that you fully understand how to operate this shower before use, read all operating instructions and retain this guide for future reference.
6. This product is not intended for use by persons (including children) with reduced physical, sensory or mental capabilities, or lack of experience and knowledge, unless they have been given supervision or instruction concerning the use of the product by a person responsible for their safety.
7. Children should be supervised to ensure that they do not play with the product.
8. **DO NOT** perform any unspecified modifications to the shower or its accessories. When servicing only use genuine Kohler Mira replacement parts.
9. **DO NOT** fit any form of outlet flow control. Only Mira recommended outlet fittings should be used.
10. **DO NOT** operate the temperature control rapidly, allow 10 – 15 seconds for the temperature to stabilise before use.
11. Care is required when adjusting flow or temperature, make sure that the temperature has stabilised.
12. Care is required if the product is turned off and back on during showering as this may result in unstable temperature. Ensure temperature has stabilised before re-using product.
13. Sunburn or skin conditions can increase your sensitivity to hot water. Make sure that you set the shower to a cooler temperature.
14. The water supplies to this product must be isolated if the product is not to be used for a long period of time. If the product or pipework is at risk of freezing during this period they should also be drained of water.
15. When this product has reached the end of its serviceable life, it should be disposed of in a safe manner, in accordance with current local authority recycling, or waste disposal policy.

PACK CONTENTS

Tick the appropriate boxes to familiarise yourself with the part names and to confirm that the parts are included.

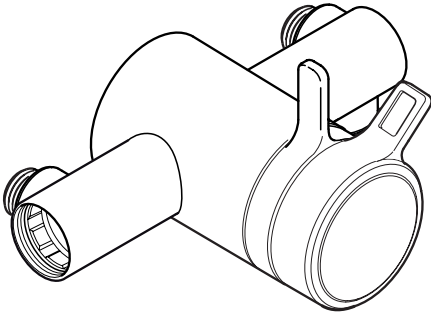

1 x Mira Select Flex Exposed Shower Control



2 x Screws, No 8 x 1 1/4"



2 x Wall Plugs



2 x Securing Clips



2 x Concealing Caps



1 x 12 L/Min Flow Regulator



2 x Concealing Plates

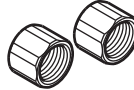

2 x Compression Nuts



2 x Olives



1 x Hexagon Key, 2.5 mm



1 x 'O' Key

Documentation

- 1 x Installation Template
- 1 x TMV2 Requirements Manual
- 1 x TMV3 Requirements Manual

SPECIFICATIONS

For Type 2 and Type 3 Valves, the supply conditions specified in the TMV2 and TMV3 Requirements Manual take precedence over the operating parameters which follow.

Pressures

- Max Static Pressure: **10 Bar**.
- Max Maintained Pressure: **5 Bar**.
- Min Maintained Pressure (Gravity System): **0.1 Bar** (0.1 bar = 1 Metre head from cold tank base to showerhead outlet).

Note! For gravity fed or other low pressure systems (0.5 bar or below) do not fit the outlet flow regulator (where applicable).

- For optimum performance supplies should be nominally equal.

Note! For combination type boilers it may be necessary to fit the flow regulator (supplied) to restrict the flow through the boiler to ensure it produces a sufficiently hot water temperature.

Temperatures

- Factory Pre-set (Blend) Shower: **41°C**.
- Optimum Thermostatic Control Range: **35°C to 43°C** (achieved with supplies of 15°C cold, 65°C hot and nominally equal pressures).
- Recommended Hot Supply: **60°C to 65°C Note!** The mixing valve can operate at higher temperatures for short periods without damage, however this could detrimentally affect thermostatic performance. For safety and performance reasons it is recommended that the maximum hot water temperature is limited to 65°C.
- Cold Water Range: up to **25°C**.
- Minimum Recommended Differential between Hot Supply and Outlet Temperature: **12°C at desired flow rate**.

Thermostatic Shut-down

- For safety and comfort the thermostat will shut off the mixing valve **within 2 Seconds** if either supply fails (achieved only if the blend temperature has a minimum differential of 12°C from either supply temperature).

Connections

- Inlets: 15 mm Compression.
- Outlet: ½" BSP Flat Face (Exposed models), 15 mm Compression (Built-in models)
- Standard connections are: **hot - left, cold - right, outlet - bottom (Exposed models), top (Built-in models)**.

Flow Regulator Installation

Flow regulators are supplied with this product and should be fitted in High Pressure systems to either;

1. Reduce Excessive Force & Flow Rate
2. Reduce Noise through the mixer due to high or unequal pressures
3. Stabilise incoming supply temperatures

Important! The fitting of flow regulators will invalidate any TMV2/3 compliance due to the minimum flow rate requirements. Do not fit the flow regulator in TMV2/3 applications.

Flow Rates

Typical Flow Rates on Low Pressure Systems, Mira Select Flex with Mira Select Flex Shower Fittings:

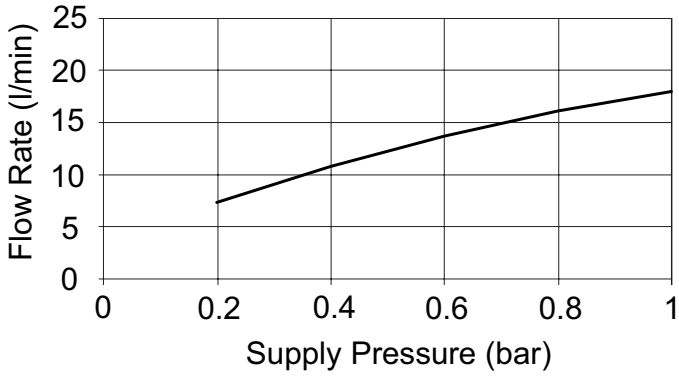

Typical Flow Rates on High Pressure Systems (with 12 Litre/Min flow regulator fitted in shower control outlet), Mira Select Flex with Mira Select Flex Shower Fittings:

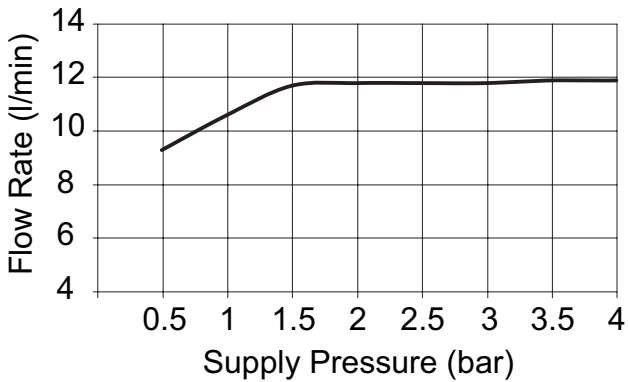

DIMENSIONS

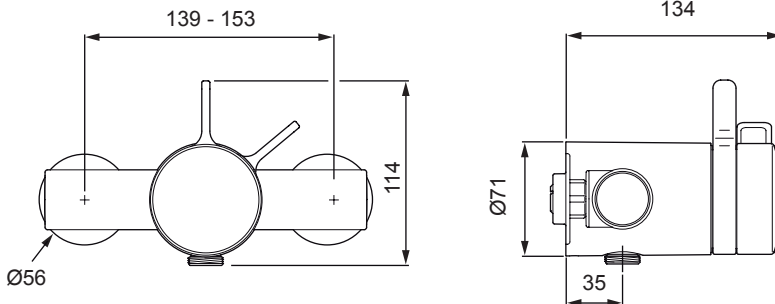

All dimensions are in mm.

INSTALLATION

Suitable Plumbing Systems

Gravity Fed:

The thermostatic mixer must be fed from a cold water cistern (usually fitted in the loft space) and a hot water cylinder (usually fitted in the airing cupboard) providing nominally equal pressures.

Gas Heated System:

The thermostatic mixer can be installed with a combination boiler.

Unvented Mains Pressure System:

The thermostatic mixer can be installed with an unvented, stored hot water system.

Mains Pressurised Instantaneous Hot Water System:

The thermostatic mixer can be installed with systems of this type with balanced pressures.

Pumped System:

The thermostatic mixer can be installed with an inlet pump (twin impeller). The pump must be installed on the floor next to the hot water cylinder.

General

Installation must be carried out in accordance with these instructions, and must be conducted by designated, qualified and competent personnel.

The installation must comply with the "Water Supply Regulations 1999 (Water Fittings)" or any particular regulations and practices, specified by the local water company or water undertakers.

Note! Make sure that all site requirements correspond to the information given in section: '**Specifications**'. For Type 2 and Type 3 Valves see also supply conditions in the TMV2 and TMV3 Requirements Manual

1. The product must not be installed in an area where it may freeze. Pipework to the product that could become frozen must be properly insulated.
2. Do not install the product in a position in which service access is restricted.
3. For stud partitions alternative fixings may be required.
4. Isolating valves must be installed close to the product for ease of maintenance.
5. Pipework must be rigidly supported and avoid any strain on the connections.
6. Pipework dead-legs should be kept to a minimum.
7. If pipework enters the product from the rear through a hole in the wall, provision must be made to prevent water ingress back into the wall structure.
8. The position of the shower and shower fittings must provide a minimum gap of 25 mm between the showerhead and the spill over level of any bath, shower tray or basin and a minimum gap of 30 mm between the showerhead and the spill over level of any toilet, bidet or other appliance with a Fluid Category 5 backflow risk (see diagram).

Note! There will be occasions when the hose retaining ring will not provide a suitable solution for Fluid Category 3 installations, in these instances an outlet double checkvalve must be fitted, this will increase the required supply pressure typically by 10kPa (0.1 bar). Double checkvalves fitted in the inlet supply to the appliance cause a pressure build up, which affect the maximum static inlet pressure for the appliance and must not be fitted. For Fluid category 5 double checkvalves are not suitable.

9. The showerhead should be positioned so that it discharges down the centre line of the bath or across the opening of a shower cubicle.
10. Only use the inlet connections supplied with the product. **DO NOT** use any other type of fittings.
11. All pipework must be checked for leaks before the product installation is completed. The product should be pressurised & the inlet & outlet connections inspected.

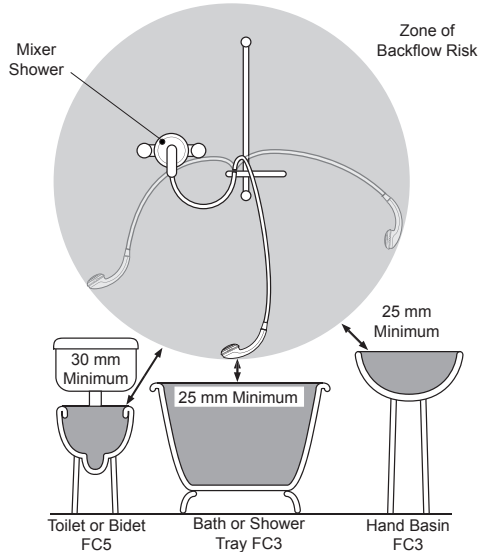

12. **DO NOT** overtighten connections, screws or grubscrews as product damage may occur.
13. Upon completion of installation, or if the product is dismantled during installation or servicing, then the product must be inspected to ensure that there are no leaks.
14. Having completed the installation, make sure that the user is familiar with the operation of the product.

Exposed Thermostatic Mixers

Installing the Thermostatic Mixer

1. The thermostatic mixer can be installed with rear, rising or falling supply inlets. Decide on the most appropriate method for your installation, and if necessary, loosen the grubscrews and rotate the inlet elbows to suit.

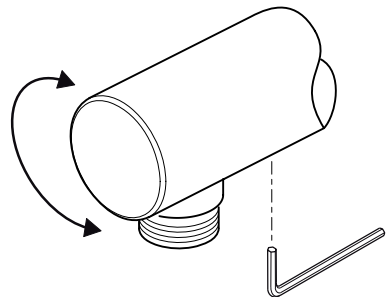

Important! Make sure that the elbows are pushed fully onto the mixer before tightening the grubscrews, **do not** overtighten.

- Use the installation template to mark the positions of the holes for the backplate and the pipe centres.

For rising or falling supplies the pipe positions should be set 35 mm from the centre of pipe to the finished wall at 153 mm centres.

Note! Allow a minimum of 150 mm either side of the mixer to allow servicing of the hot and cold inlet filters.

Note! The thermostatic mixer has adjustable inlets to fit existing pipework centres between 139 mm and 153 mm.

- For solid walls drill the holes for the backplate with a 6 mm drill and insert the wall plugs. For other types of wall structure alternative fixings may be required (not supplied).

4. For Rear Entry Supplies Only:

- Drill the holes for the supply pipes at 153 mm centres.
- Recess the inlet holes $\text{Ø}32 \text{ mm} \times 10 \text{ mm}$ deep to allow for the concealing plates.

Note! Depth must be sufficient to prevent the concealing plates fouling on the plumbing elbows.

- Fit the supply pipework: **Hot - Left, Cold - Right**. The inlet pipework should extend 13 mm from the finished wall surface.

Note! If it is not possible to install the mixer with this pipework configuration complete the installation then refer to section: ‘Reversed Inlet Supplies’.

- Remove the backplate from the mixer by loosening the grub screw with a 2.5 mm hexagonal key.
- Secure the backplate to the wall using the screws.

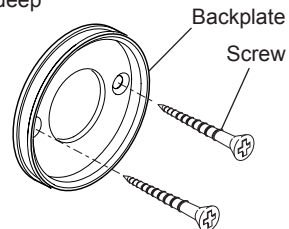
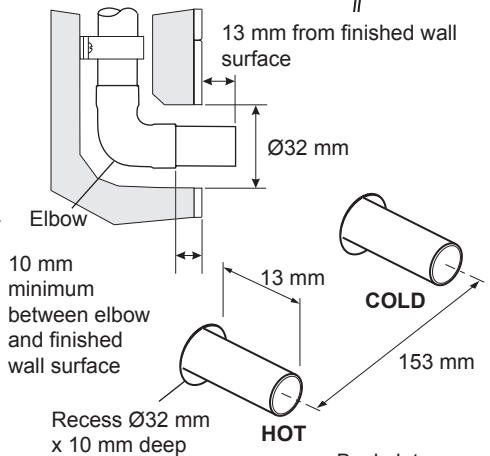
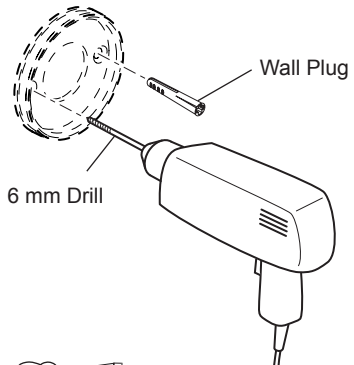
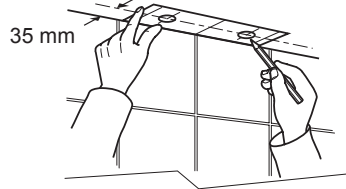
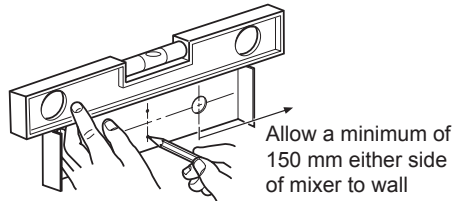

8. For Rear Entry Supplies Only:

- a) Fit the concealing plates over the inlet pipes.

Note! Apply silicone sealant to the back face of the flange.

9. **Caution! It is essential at this point that the supply pipework is thoroughly flushed through before connection to the mixer.** Failure to do so may result in product malfunction and will not be covered under the guarantee.

10. Fit the compression nuts and olives onto the pipework.

11. Align the mixer with the pipework and fit onto the backplate. Minor misalignment of the pipework can be accommodated by the inlets, which are adjustable between 139 and 153 mm centres.

Important! Make sure that the hot and cold inlets on the mixer correspond with the hot and cold inlet supplies.

12. Using a suitable tool, tighten the waterway securing ring until it abuts the adjustable inlet preventing outward movement.

13. Assemble the concealing caps and securing clips and push into the elbow.

14. Tighten the compression nuts onto the mixer with a suitable spanner.

Caution! Take care not to damage the chrome surfaces.

15. Tighten the grub screw to secure the mixer to the backplate.

16. Fit the shower fittings, refer to your shower fittings installation and user guide for instructions.

Note! For high pressure systems (above 0.5 bar) make sure that the flow regulator (supplied) is fitted inside the outlet nipple (refer to illustration).

Important! The fitting of this flow regulator will invalidate any TMV2 or TMV3 compliance due to the minimum flow rate requirements. Do not fit the flow regulator in TMV2 and TMV3 applications.

17. Turn on the hot and cold water supplies and check for leaks.

18. Before using the shower, refer to section: '**Commissioning**'.

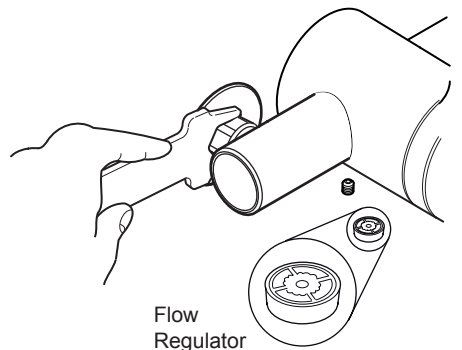
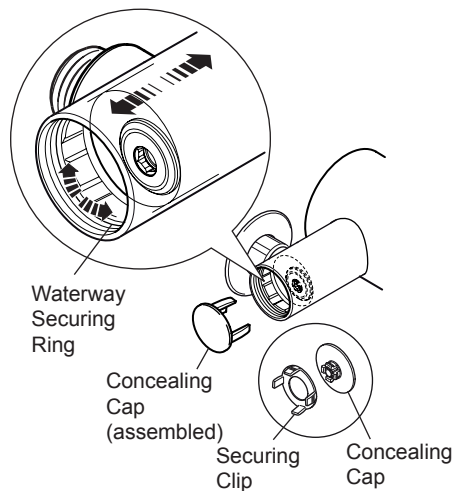
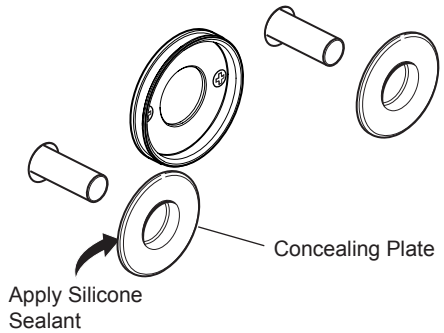

REVERSED INLET SUPPLIES

The Mira Select Flex thermostatic mixer is supplied with inlet connections **Hot - Left, Cold - Right** and **Outlet - Bottom** (exposed models), **Outlet - Top** (built-in models) as standard. If the hot and cold water supply pipes have been reversed during installation, the thermostatic cartridge must be removed and rotated 180°.

Exposed Models

1. Isolate the hot and cold water supplies and operate the flow control lever to relieve pressure and drain any residual water.
2. Unscrew the grub screw with a 2.5 mm hexagonal key and pull off the temperature control and flow control levers.
3. Pull off the bearing.
4. Rotate the white section of the control lever interface 90° clockwise and pull off.
5. Pull off the flow lever adaptor.
6. Locate the 'O' key (supplied) onto the cartridge nut and turn anticlockwise. Unscrew fully and pull the cartridge from the mixer body.
7. Rotate the cartridge 180°.

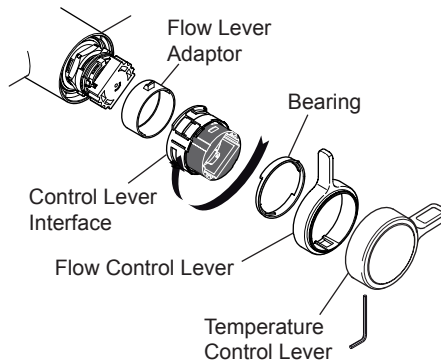

8. Make sure that the two inlet seals are fitted and carefully push the cartridge back into the mixer body, aligning the lugs into the slots.
Note! Check that the cartridge lug stamped 'H' is aligned with the hot inlet supply.
Important! Take care when fitting the cartridge. Damage to the cartridge inlet seals may result in dripping from the showerhead.
9. Tighten the nut by turning the 'O' key clockwise.
10. Refit the controls in reverse order. Before using the shower, refer to section: '**Commissioning**'.

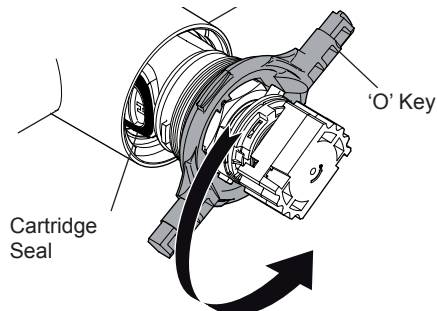

OPERATION

The **Mira Select Flex** is a thermostatic mixer with separate control levers for on/off and temperature.

Turn the Flow Control Lever **anticlockwise** to the preset maximum flow

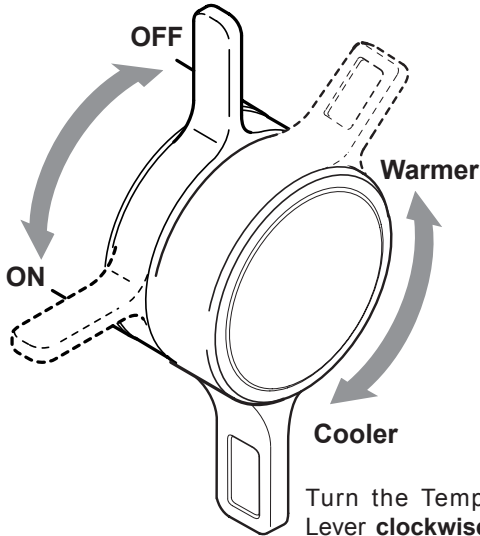

Turn the Temperature Control Lever **clockwise** to decrease the temperature and **anticlockwise** to the preset maximum temperature

COMMISSIONING

Commissioning must be carried out in accordance with these instructions, and must be conducted by designated, qualified and competent personnel.

Exercising the Thermostat

Thermostatic mixing valves with wax thermostats are inclined to lose their responsiveness if not used. Valves which have been in storage, installed but not commissioned, or simply not used for some time should be exercised before setting the maximum temperature or carrying out any tests.

A simple way to provide this exercise is:

- (a) Make sure that the hot and cold water are available at the valve inlets, and the outlet is open.
- (b) Move the temperature control rapidly from cold to hot and hot back to cold several times, pausing at each extreme.

Maximum Temperature

Note! For Type 2 and Type 3 valves in healthcare installations the maximum blend temperature is determined by the application, refer to the TMV2 or TMV3 Requirements Manual.

The maximum blend temperature obtainable by the user should be limited, to prevent accidental selection of a temperature that is too hot.

All Mira Thermostatic mixing valves are fully performance tested and the maximum temperature is preset to approximately 41°C under ideal installation conditions at the factory.

Site conditions and personal preference may dictate that the maximum temperature has to be reset following installation.

Temperatures should always be recorded using a thermometer with proven accuracy.

Maximum Temperature Setting

Before using the shower, the maximum temperature level must be checked to make sure that it is safe. It has been preset to approximately 41°C at the factory, but due to variations in site conditions the maximum temperature may need adjustment.

Note! Make sure that the hot water temperature is at least 55°C and that there is a sufficient supply.

1. Turn on the shower to maximum flow and temperature (i.e. both controls fully anticlockwise) and allow the temperature to stabilise.

If the temperature is too hot or too cold adjust as follows:

2. Using a 2.5 mm Hexagon Key (supplied), unscrew and remove the Temperature Control Lever.
3. Insert the 2.5 mm Hexagon Key into the centre of the Green Hub and engage with the hidden Temperature Adjust Screw.
4. Turn the Hexagon Key until the required maximum showering temperature is obtained. Turn anticlockwise to increase or clockwise to decrease the temperature ($\frac{1}{4}$ turn = approximately 1°C).

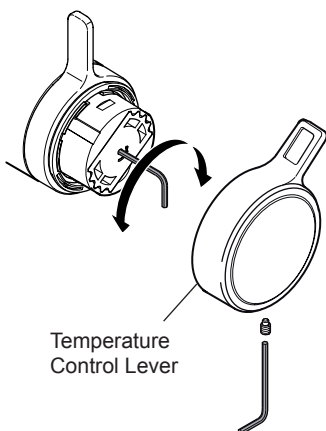

5. Once the desired maximum blend temperature has been achieved, turn off the shower.
6. Refit the Temperature Control Lever.
7. Check that the showering temperature is correct.

FAULT DIAGNOSIS

Fault Diagnosis

Symptom:

- Only hot or cold water from the mixer outlet.
- Outlet temperature too hot / too cold.

Cause Rectification:

- Inlets reversed (hot supply to cold supply). Refer to section: '**Reversed Inlet Supplies**'.
 - No hot water reaching mixer.
 - Check the filters for any blockage refer to section '**Maintenance**'.
 - Installation conditions outside operating parameters, refer to sections: '**Specifications**' and '**Commissioning**'.
 - **If the temperature is too cold and you have a combination type boiler it may not be producing sufficiently hot water at desired flow rate (refer to 'Specifications'). Fit flow regulator (supplied) to shower valve outlet. For more information contact Mira Showers or visit the website.**
-

Symptom:

- Fluctuating or reduced flow rate.

Cause Rectification:

- Check the showerhead, hose and filters for any blockage.
 - Make sure that the maintained inlet pressures are nominally balanced and sufficient, refer to section: '**Specifications**'.
 - Make sure that the inlet temperature differentials are sufficient, refer to section: '**Specifications**'.
 - Air lock or partial blockage in the pipework.
 - Flow regulator fitted incorrectly.
-

Symptom:

- Water leaking from the showerhead.

Cause Rectification:

- Normal for a short period after shut off.
- Check that the pressures are not in excess of the specifications for the product.
- Renew the thermostatic cartridge.

MAINTENANCE

General

This Product is precision engineered and should give continued safe and controlled performance, provided:

1. It is installed, commissioned, operated and maintained in accordance with manufacturers recommendations.
2. Periodic attention is given, when necessary, to maintain the product in good functional order.

The Mira Select Flex Thermostatic Mixer is designed for the minimum of maintenance in normal use. The only serviceable parts are the inlet filters which should be checked and cleaned every 12 months. If a malfunction occurs with the Thermostatic Cartridge then this will necessitate a complete cartridge replacement.

Note! The cartridge contains no internally serviceable parts.

If you require a Rada trained engineer or agent, refer to section: 'Customer Service'.

Planned Maintenance

Important! For Type 3 Valves use the In-Service Tests given in the TMV3 Requirements Manual. In the absence of any other instruction or guidance on the means of determining the appropriate frequency of in-service testing, the procedure contained within this guide (taken from Annex F of D08) should be used. For Type 2 Valves use the In-Service Tests given in the TMV2 Requirements Manual.

For other commercial installations it is recommended that the correct blend setting is checked every 6 months and that the In-Service Test procedure is followed every 12 months.

Lubricants

Silicone based lubricants must only be used on the rubber seals.

Caution! Oil based or other lubricant types may cause rapid deterioration of seals.

Cleaning

The chrome plated parts should be cleaned using a mild washing up detergent or soap solution, rinsed and then wiped dry with a soft cloth.

Warning! Many household cleaners contain abrasive and chemical substances, and should not be used for cleaning plated or plastic fittings.

Do not use descalents on this product.

Inlet Filters

The inlet filters should be checked and cleaned as necessary every 12 months.

Note! The inlet filters must not be removed except for cleaning. If the thermostatic mixer is operated without the inlet filters fitted the warranty on the product will be void.

1. Isolate the hot and cold water supplies and operate the flow control lever to drain any residual water.
2. Carefully remove the concealing caps and unscrew the filter plugs with a 5 mm hexagonal wrench. Remove the filters.

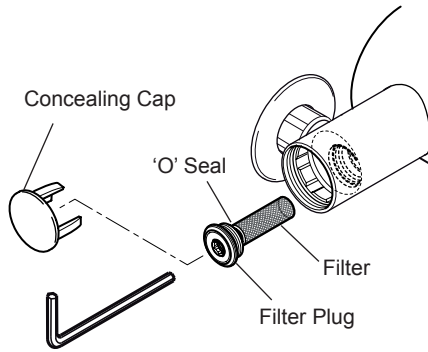

3. Clean the filters under a jet of water to remove any lodged particles.
 4. Refit the filters and tighten the filter plugs.
- Note!** Make sure that the 'O' seal is fitted correctly and undamaged.
5. Turn on the hot and cold water supplies and check for leaks.
 6. Refit the concealing caps.

SPARE PARTS

Note! All spare parts supplied individually unless stated otherwise.

Exposed Models

- 1595.067 Screw Pack (identified 'A')
- 1679.044 Seal Pack (identified 'B')

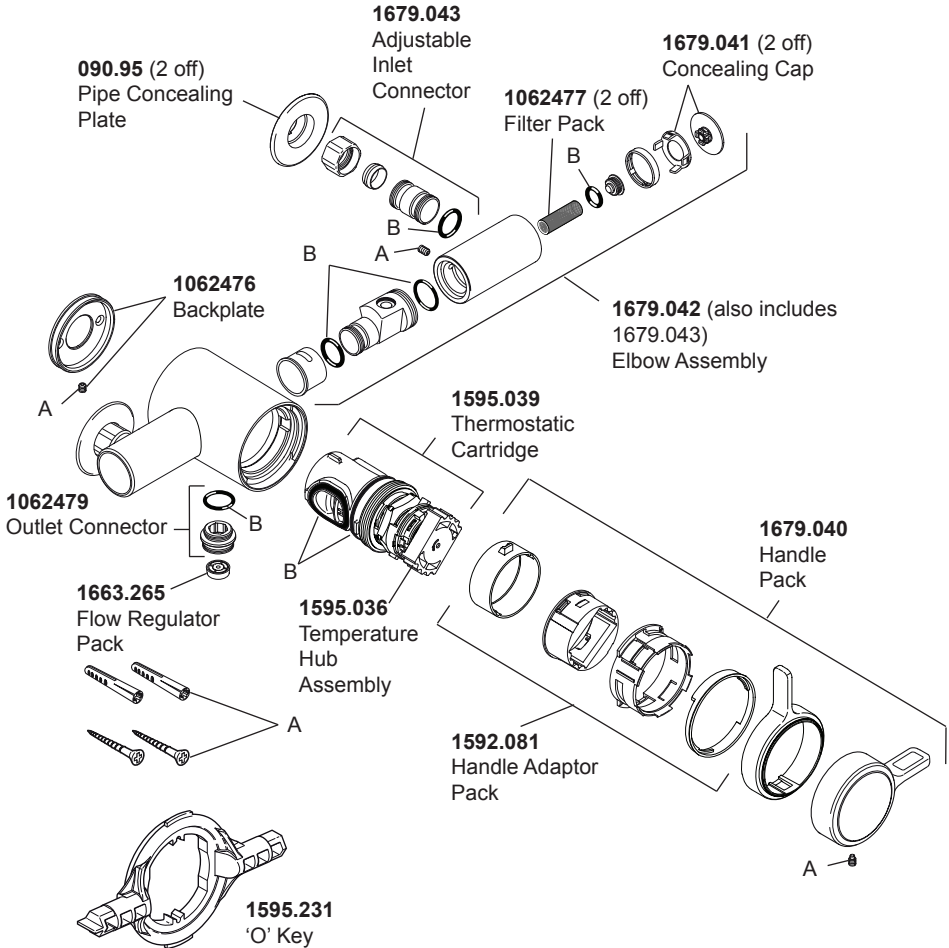

NOTES

CUSTOMER SERVICE

Guarantee

Your product has the benefit of our manufacturer's guarantee which starts from the date of purchase.

To activate this guarantee, please return your completed registration card, visit our website or free phone 0800 0731248 within 30 days of purchase (UK only).

Within the guarantee period we will resolve defects in materials or workmanship, free of charge, by repairing or replacing parts or product as we may choose.

This guarantee is in addition to your statutory rights and is subject to the following conditions:

- The guarantee applies solely to the original installation under normal use and to the original purchaser only. The product must be installed and maintained in accordance with the instructions given in this user guide.
- Servicing must only be undertaken by us or our appointed representative. **Note!** if a service visit is required the product must be fully installed and connected to services.
- Repair under this guarantee does not extend the original expiry date. The guarantee on any replacement parts or product ends at the original expiry date.
- For shower fittings or consumable items we reserve the right to supply replacement parts only.

The guarantee does not cover:

- Call out charges for non product faults (such as damage or performance issues arising from incorrect installation, improper use, inappropriate cleaning, lack of maintenance, build up of limescale, frost damage, corrosion, system debris or blocked filters) or where no fault has been found with the product.
- Water or electrical supply, waste and isolation issues.
- Compensation for loss of use of the product or consequential loss of any kind.
- Damage or defects caused if the product is repaired or modified by persons not authorised by us or our appointed representative.
- Routine maintenance or replacement parts to comply with the requirements of the TMV 2 or TMV 3 healthcare schemes.
- Accidental or wilful damage.
- Products purchased ex-showroom display.

What to do if something goes wrong

If your product does not work correctly refer to this manual for fault diagnosis and check that it is installed and commissioned in accordance with our instructions. If this does not resolve the issue, contact us for help and advice.

Extended Guarantees

A selection of protection plans are available that enable you to cover repair bills (excludes Eire). Ring 01922 471763 for more details.



Helpdesk Service - Ring our Customer Services Team for product advice, to purchase spare parts or accessories or to set up service visit. You can contact us via phone or e-mail, details below. Please provide your model name, power rating (if applicable) and date of purchase.



Mira Showers Website (www.mirashowers.co.uk)

Visit our website to register your guarantee, download user guides, diagnose faults, purchase our full range of accessories and popular spares, or request a service visit.



Spares and Accessories - We hold the largest stocks of genuine Mira spares and accessories. Contact us for a price or visit our website to purchase items from our accessory range and popular spares.



Service/Repairs - No one knows our products better than our nationwide team of Service Technicians. We can carry out service or repair work to your product both during and after the guarantee period. Ask about our fixed price service repairs.

To Contact Us:



01685 898110



E-mail: sales@wetroomsdirect.net

Visit: www.wetroomsdirect.net

Mira is a registered trade mark of
Kohler Mira Limited.

The company reserves the right to alter
product specifications without notice.

